



Captair 391 Smart

Ductless filtering fume hoods

Safer to operate with Smart Technology that includes:

- Erlab's advanced carbon filtration technology and/or HEPA/ULPA accomodates your specific needs
- Meets AFNOR NFX 15 211/ANSI Z9.5-2012 filtration efficiency standard (class 1 and 2)
- Sensors that detect filter breakthrough of solvents, acids or formaldehyde
- Safety back up filter in case of main filter saturation
- Continuous monitoring of air face velocity
- Erlab Safety Program: application analysis and validation, usage certification, filter change reminders
- Connect with eGuard™ for real-time status, notifications and alerts

Simpler to use with Smart-Light™

With Smart-Light, you can easily see that the hood is operating safely. Should the light pulse, you are notified that:

- Containment has been compromised or,
- The filter has breakthrough or,
- There is a fan failure

Flexibility

- The configurable filtration column will accomodate application changes
- No ductwork needed. This allows you to move the hood anywhere

Savings

- No ductwork cost
- Annual energy costs decrease significantly
- Energy savings outweigh filter replacement costs

Environment

- No dangerous chemicals are released into the atmosphere
- Low energy consumption



You get the highest level of filtration performance



Smart-Light keeps you safe



Connect your equipment and download the eGuard App for remote access



Download our eGuard application



Captair 391 Smart

Ductless Filtering Fume Hoods

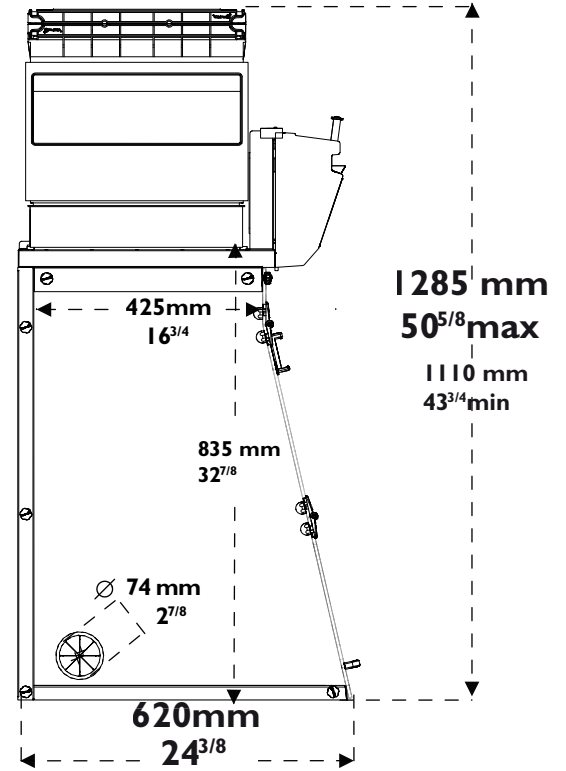
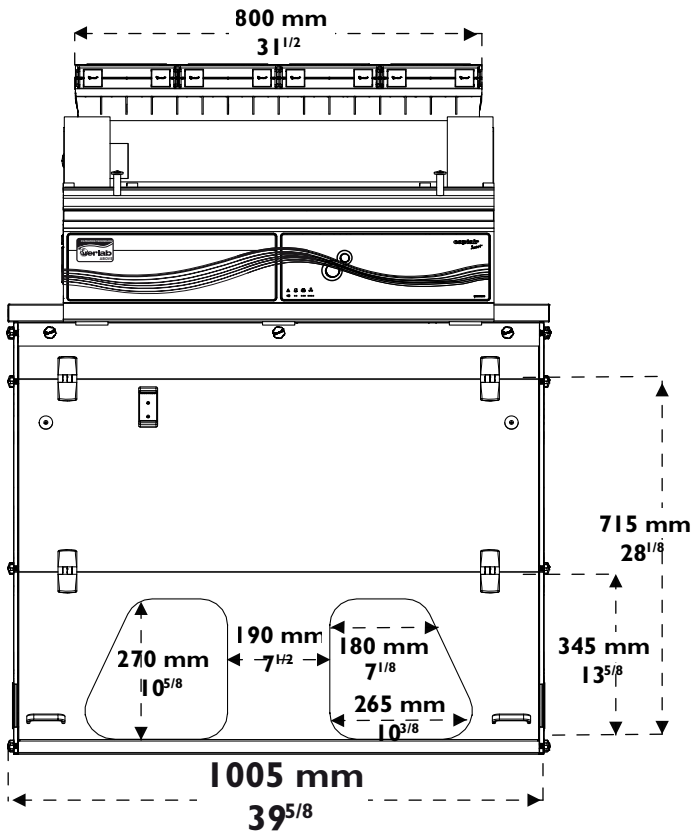

Heights according to the filtration column configuration

Type 1C or 1P	1110 mm (43 3/4)	Please add 150mm (5 7/8) between the last filter and the ceiling to allow a good air recirculation and to replace filters easily
Type 2C or 1P1C or 1C1P	1205 mm (47 1/2)	
Type 1P2C or 1P1C1P	1285 mm (50 5/8)	

Work surfaces with built in spill tray

Tempered glass

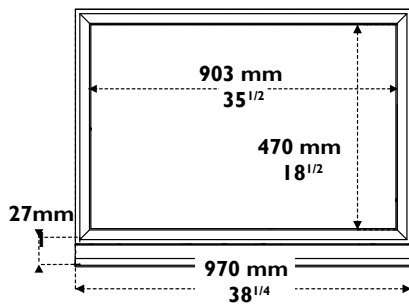

Phenolic resin

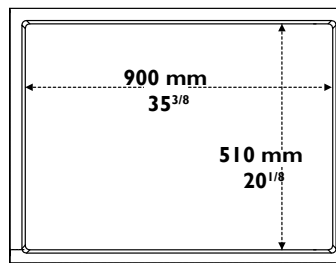

304 L stainless steel

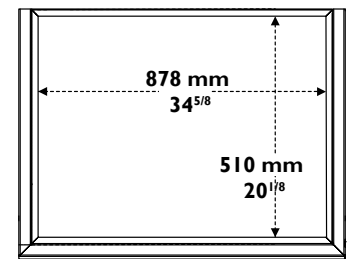

Benchcap: fixed work bench

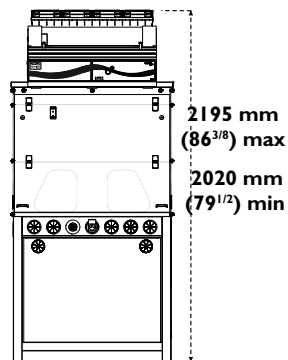

Mobicap: mobile rolling cart

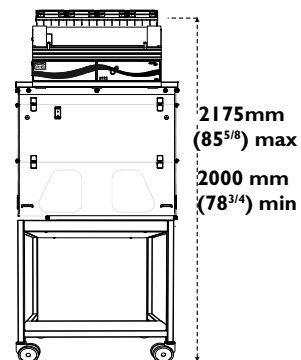



Designed with you in mind: our filtration column can be configured for your specific application requirements

		Products handled / Applications			
		Liquid chemical handlings	Powder weighing	Liquid chemical and powder handlings	Liquid chemical handlings in clean room
Customized filtration column	Class 1 according to the NF X 15-211	 2C	NA	 1P2C	 2C1P
	Class 2 according to the NF X 15-211	 1C	 1P	 1P1C	 1C1P

C	P	
Carbon filtration for gases and vapors AS:For organic vapours BE+: Polyvalent for acid + organic vapors F:For formaldehyde vapours K:For ammonia vapours	Particulate filtration for powders HEPA H14:99.995 % efficiency filtration of particles over 0.1 µm in size ULPA U17:99.999995 % efficiency filtration of particles over 0.1 µm in size	Molecode Automatic alarm to detect filter saturation

Specifications

Safety Standards	AFNOR NF X 15-211:2009: France - BS 7989: England DIN 12 927:Germany - EN 1822:1998 (HEPA H14 & ULPA U17 Filters) - CE Marking
Air Flow	220 m3/h / 129 CFM
Air Face Velocity	0.4 to 0.6 m/s / 79 fpm to 118 fpm
Voltage/Frequency	90 - 220V / 50-60Hz
Power consumption	65 W
Sash openings	The oblong shape allows for proper containment and ergonomic mobility
Structure	Corrosion resistant electro-galvanized steel coated with anti-acid polymer
Side and front panels	Chemical resistant acrylic
Filtration module	Polypropylene

Features

Smart-Light	When the light is pulsing: indicates that containment is compromised, or there is filter breakthrough, or there is a fan failure
Filtration technology	1 column that can be configured to handle liquids, powders, or both
Carbon filtration for gases and vapours	Depending on the filtration column / configuration (see table above)
Particulate filtration for powders	Depending on the filtration column configuration (see table above)
eGuard app (Android or iOS)	For remote control to monitor the hood status, change the settings, and deliver safety alerts immediately to your devices (mobile, tablet and PC)
Internal lighting	LED lighting > 650 Lux
Anemometer	Hot-wire anemometer will alarm if the face velocity decreases
Chemical Listing	List of most commonly used chemicals (NIOSH) and their retention capacity by our filters

Accessories

Work Surfaces	Phenolic Resin, Glass, or 304L Stainless Steel
Molecode	Detection sensor: Type S, for solvents / Type A, for acids / Type F, for formaldehyde
Benches	Rolling cart (Mobicap) or fixed bench (Benchcap)
Particulate Pre-filter	Protects the main filter(s) from dust
Transparent Back Panel	Clear acrylic panel for easy viewing



Erlab's state of the art Research & Development Laboratory relying exclusively on filtration

North America

+1 800-964-4434 | captairsales@erlab.com

China

+86 (0) 512 5781 4085 | sales.china@erlab.com.cn

France

+33 (0) 2 32 09 55 80 | ventes@erlab.net

Germany

0800 330 47 31 | verkauf@erlab.net

Italy

+39 (0) 2 89 00 771 | vendite@erlab.net

Malaysia

+60 (0) 7 3 555 724 | erlab@tm.net.my

Spain

+34 93 673 24 74 | ventas@erlab.net

United Kingdom

+44 (0) 1722 341 940 | salesuk@erlab.net

www.erlab.com

About Erlab

We provide safety, we protect your health

Erlab invented the ductless fume hood in 1968. With more than 45 years of experience in the field of chemical filtration and protection of laboratory personnel; we know the formula for safety. With Erlab, you will never have to wonder or worry if our products are safe. We build each one of the following 7 ingredients into our products, and without all of them, your health and safety will be compromised.

1 Erlab R&D Laboratory

The engineers and chemists in our state-of-the-art R&D laboratory understand molecular filtration. We are committed to designing products that are safe and of the highest quality, strive to improve our products, and continuously develop new products that provide greater protection in the laboratory.

2 Strict Safety Standards

We hold ourselves to the highest standard and adhere to the strict AFNOR NF X 15-211: 2009 filtration safety standard as endorsed by ANSI Z9.5-2012.

3 A Published Chemical Listing

It all begins here. Without this listing, we are not compliant with AFNOR NFX 15-211. Our in-house laboratory tests, as well as independent testing to verify the retention capacity of over 700 chemicals for our filters.

4 Independent Testing

Erlab filters have been independently tested multiple times at various concentrations guaranteeing that our safety solutions all adhere to the strict performance criteria of the AFNOR NF X 15-211:2009 standard assuring that the emission concentration at the filter exhaust will always be lower than 1% of the TLV.

5 Application Questionnaire (Valiquest)

Our laboratory specialists will recommend the appropriate filtration fume hood, type of filter, and personalized advice.

6 Certificate of Validation for the chemicals used in the hood

A certified PhD chemist issues a Certificate of Validation with a list of the chemicals approved for use in the hood.

7 Our Safety Program

We back up our products 100%. This program includes your specialized chemical evaluation, validation of your hood upon installation, and a filtration safety specialist at your service to ensure that your hood is operating to its full potential.